

Versatile Refueling Filter

Product Bulletin

FBO Filter Assembly

Racor Hydrocarbon Filters' new FBO-10 and FBO-14 filter assemblies were designed to meet the toughest hydrocarbon refueling conditions and give maintenance personnel ease of filter change outs. The FBO Assembly can flow 25 gpm/95 lpm or up to 60gpm/230 lpm depending on the unit, elements installed and fuels being filtered.

The FBO assembly can be used on mobile refuelers or installed in refueling cabinets. The unit can also be used for diesel fuel dispensing pumps or as a primary fuel filter/water separator for large diesel engines.

The assembly features a "locking ring collar", which attaches the filter housing to the aluminum die cast filter head with four bolts. The slotted "locking ring collar" allows maintenance personnel to hand loosen the four collar bolts, rotate and lower the bowl assembly for element change outs. With new element installed, simply raise the bowl and rotate into position on the locking ring and hand tighten evenly.

The closure hardware consists of stainless steel nuts, bolts, and washers with metal hand knobs for ease of maintenance. No wrenches or other special tools required.

No V-Band Clamps are used allowing one person to easily change the filter element.

Applications:

- Jet fuel, Aviation gas, diesel fuel, gasoline, kerosene, JP4, JP5 and JP8.

Installations:

- Aviation fuel trucks
- Aviation fueling cabinets
- Diesel fuel dispensing system
- Marine fuel docks
- Fuel systems on large diesel engines

Standard Design Features:

- Die-cast aluminum head
- Steel filter bowl assembly
- Powder coated components
- "Locking ring collar", no clamps
- 1 1/2" NPT Inlet and Outlet
- 150psi @ 240°F max design pressure
- Manual drain valve
- Manual vent valve



Optional Accessories:

- Water sight glass or electronic water probe
- Delta P indicator

Element Options: (micron)

- FP Prefilters: 1, 5, 10 & 25
- OCP Coalescers: 1, 5, 10, & 25
- FW Water Absorbing: 1, 5, 10, & 25

1/31/03

FBO-10	Maximum Flow Rates				Clean Dry	Change
	Flow Range	Diesel	Jet Fuel	Gasoline	Delta P	Delta P
Prefilter	5-40 GPM	20	40	50	**	20 PSID
Filter Sepa	5-35 GPM	18	35	45	**	15 PSID
Absorber	5-25 GPM	18	35	45	**	30 PSID

FBO-14	Maximum Flow Rates				Clean Dry	Change
	Flow Range	Diesel	Jet Fuel	Gasoline	Delta P	Delta P
Prefilter	10-60 GPM	30	60	75	**	20 PSID
Filter Sepa	10-50 GPM	25	50	65	**	15 PSID
Absorber	10-37 GPM	26	55	70	**	30 PSID

**varies with fluid and flow rate

FBO-10 and FBO-14 Specifications

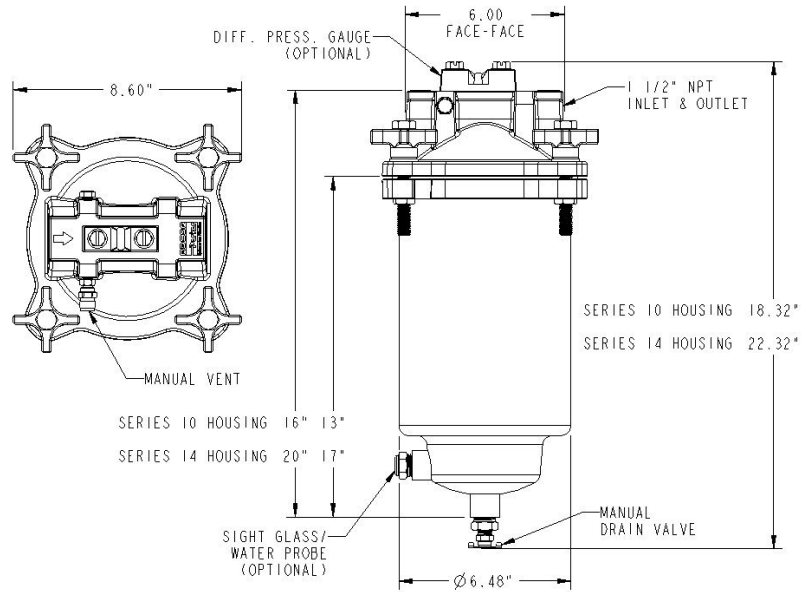

Element Applications

	Micron Rating	FBO-10	FBO-14
		6 X 10 Element	6 X 14 Element
Filter Separator	1	FBO-60327	FBO-60336
	5	FBO-60328	FBO-60337
	10	FBO-60353	FBO-60356
	25	FBO-60329	FBO-60338
Prefilter	1	FBO-60330	FBO-60339
	5	FBO-60331	FBO-60340
	10	FBO-60354	FBO-60357
	25	FBO-60332	FBO-60341
Absorptive Filter	1	FBO-60333	FBO-60342
	5	FBO-60334	FBO-60343
	10	FBO-60355	FBO-60358
	25	FBO-60335	FBO-60344

Parker Hannifin Corporation
Racor Division
301 Downing Ave.
Henryetta, OK 74497 USA
918/652-4481
800/451-7299
FAX 918/652-8882
<http://www.parker.com/racor>
PB-3

